

Measuring Eye, DMA Type

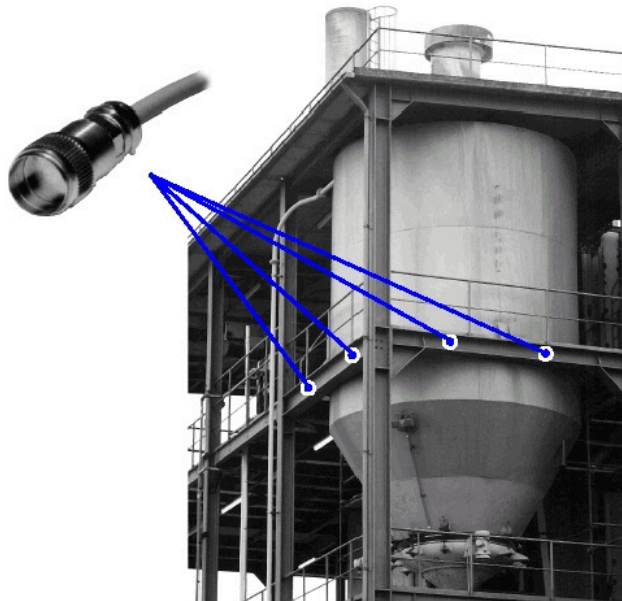

- **Compact sensor for measuring forces and masses**
- **Same sensor geometry for all load ranges**
- **Maintenance-free**
- **Hermetically sealed design, protected to IP 68**
- **High corrosion protection through use of stainless steel**
- **Easy retrofit of existing silo structures**
- **No contact between sensor and material to be weighed**
- **Use in the hazardous area possible ATEX categories 2G/2D/3D (Zones 1, 21, 22).**

Application

The DMA measuring eye has been particularly designed for use as low-priced hopper level measuring system.

With very little effort it can be retrofitted into existing structures permitting gravimetric level measurement.

Other possible applications are, for instance, pre-assembled measuring supports or beams as well as threshold messages for cranes.

Construction

The DMA measuring eye is made of stainless steel. The knurled pressing-in area on circumference transmits the deformations of the supporting structure to a web equipped with strain gauges.

Measuring body and cable outlet are connected by laser welding which produces a hermetical sealing effect.

Function

The DMA measuring eye is pressed into the supporting structure of the construction to be weighed.

When the supporting structure is loaded, the resulting deformations generate a voltage change proportional to applied load.

The following types of measuring eyes are available:

- **DMA-V:**
Standard measuring eye with complete strain gauge full bridge
- **DMA-H:**
Special variant with strain gauge half bridge (if more than 4 measuring eyes/system are used)
- **DMA-V-ÜS:**
Measuring eye with complete strain gauge full bridge and additional overvoltage protection, e.g. for use in railway tracks
- DMA-V and DMA-H are also available as **ATEX variant**.

Typical applications

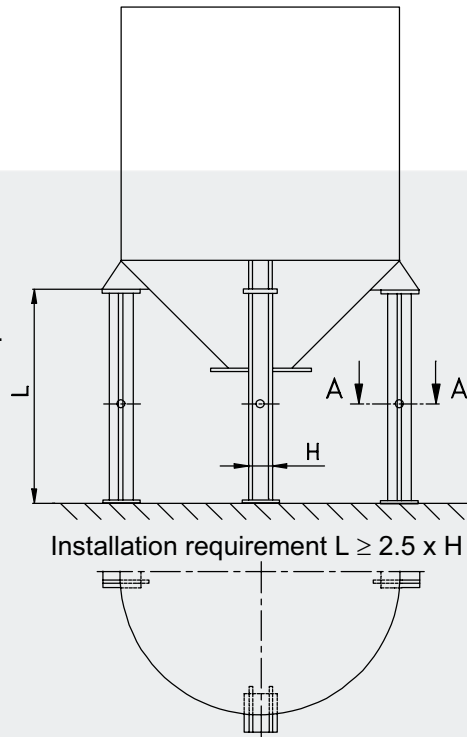

Normal force measurement:
Measuring eye mounted on vertical silo supports

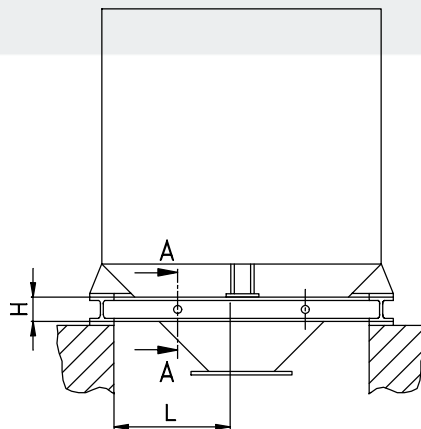
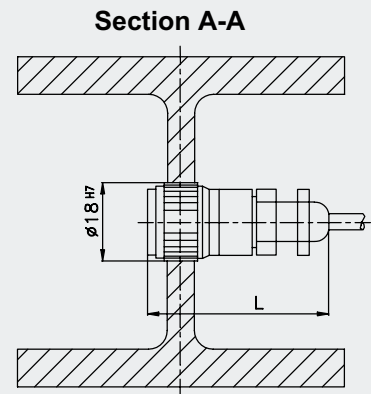

Variant	L
DMA-V DMA-H	46
DMA-V-ex	
DMA-H-ex	
DMA-V-ÜS	66

Lateral force measurement:
Measuring eye mounted on horizontal silo supports

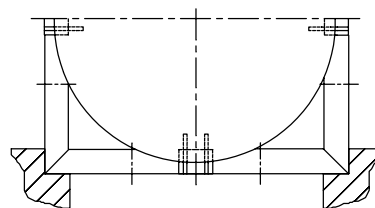

Technical Data

The technical data apply to one DMA-V measuring eye or a pair of DMA-H measuring eyes (combined to form a Wheatstone bridge).

		Measuring Eye DMA-V, DMA-V-ÜS or 2x DMA-H		ATEX-Variant
Measuring principle		Normal force measurement	Lateral force measurement	
Required rated stress	σ, τ	$\sigma \geq 30 \text{ N/mm}^2$	$\tau \geq 15 \text{ N/mm}^2$	σ, τ , see left side
Sensitivity at required rated stress	C_n	$\geq 0,3 \text{ mV/V}$		
Input resistance	R_e	380 Ω		1060 Ω
Output resistance	R_a	350 Ω		1000 Ω
Ref. supply voltage	$U_{sref.}$	10 V		
Max. supply voltage	$U_{smax.}$	12 V		
Rated temperature range	B_{tn}	- 10°C to + 40°C		
Service temperature range	B_{tu}	- 30°C to + 80°C	- 20°C to + 60°C	
Storage temperature range	B_{ts}	- 40°C to + 85°C		
Zero signal temperature coefficient	TK_o	$< 1.5 \mu \text{ V} / \text{V} / 10\text{K}$		
Material		Stainless steel		
Weight with cable		0.6 kg		
Type of protection		IP 68 (laser-welded)		
Cable specification		PVC cable $\varnothing 5.4 \times 15 \text{ m} / - 40^\circ\text{C to } + 85^\circ\text{C}$		
Connection assignment		Black: input + (82)	/	blue: input - (81)
		Red: output + (28)	/	white: output - (27)
		Green-yellow: screen		

System and switching accuracies depend on several factors, e.g. hopper geometry, installation site and measuring task. Typically, system accuracies of $\pm 0.5 \%$ for lateral force measurement and $\pm 1.5 \%$ for normal force measurement can be obtained. The switching accuracies for preset fill levels (setpoints) are approx. $\pm 0.2 \%$ (each related to full scale).

These accuracies require highly qualified engineering and proper and workmanlike installation.

We offer the measuring system layout as a special service, i.e., we determine the accuracies expected for the geometry of your application and assume warranty provided that Schenck has supplied the components and the measuring eyes are mounted by personnel authorized by Schenck.

Projection notes

To determine whether an existing hopper can be retrofitted with SCHENCK measuring eyes, calculate the rated stress as under:

- **Normal force measurement (required rated stress $\sigma \geq 30 \text{ N/mm}^2$)**

$$\text{Rated stress } \sigma \text{ in [N/mm}^2\text{]} = \frac{(\text{Mass of hopper contents in [kg]}) \times 10}{(\text{Number of supports}) \times (\text{supports cross-sectional area in [mm}^2\text{)})}$$

- **Querkraftmessung (erforderliche Nennspannung $\tau \geq 15 \text{ N/mm}^2$)**

$$\text{Rated stress } \tau \text{ in [N/mm}^2\text{]} = \frac{(\text{Mass of hopper contents in [kg]}) \times 10}{(\text{Number of cross members}) \times 2 \times (\text{cross member area in [mm}^2\text{)})}$$

Variants	Ordering No.
DMA-V Measuring eye with strain gauge full bridge	D 705 336.01
DMA-V-EX Measuring eye with strain gauge full bridge for use in ATEX categories 2G (EEx ib IIC T4) and 2D/3D (IP6x, T130°C, T195°C)	D 724 987.02
DMA-V-ÜS Measuring eye with strain gauge full bridge for use in railway tracks	D 705 336.03
DMA-H Measuring eye with strain gauge half bridge	D 705 226.01
DMA-H-EX Measuring eye with strain gauge half bridge for use in ATEX categories 2G (EEx ib IIC T4) and 2D/3D (IP6x, T130°C, T195°C)	D 724 988.01
Mounting kit for pressing-in measuring eyes	D 705 046.01
DKK69/DMA Cable junction box for connection of up to 8 measuring eyes	D 727 243.03
DKK69/DMAE Cable junction box for connection of max. 4 measuring eyes DMA-V-Ex or max. 8 measuring eyes DMA-H-Ex for use in hazardous area	D 707 102.03
Closing device to protect measuring eyes against mechanical damage (not for type DMA-V-ÜS)	D 705 968.01
Manual, German	D 707 200.01
Manual, English	D 707 204.01
Manual, French	D 707 200.02