

Load Cells VBB and Load Cell Mounts VEB



- **Highest accuracies (up to 6000 increments to OIML R60)**
- **Hermetically sealed due to laser welding (IP67)**
- **Protection to EEx ib IIC T 4 for use in explosion hazardous areas**
- **Optimized for parallel connection through perfect calibration**
- **6-wire circuit**
- **100% stainless steel**

Application

Load cells of the VBB type are designed to convert the mechanical input signal, the load, proportionally into the electrical output voltage.

Combined with the corresponding VEB elastomer mounts, they are very suitable for use with platform, batching, and hopper scales. Their compact design simplifies the integration in any existing construction.

The rugged design of the load cells and mounts ensures reliable operation even in severe environments.

Construction

Entirely made of stainless steel and hermetically sealed by laser welding, the VBB load cells are connected by using a high-quality shielded 6-wire PVC cable.

The 6-wire circuit provides for a measuring signal which is insensitive to connecting cables of different lengths.

Functions

- High calibrating accuracy, thus, optimal prerequisites for the parallel connection of load cells
- High degree of measuring signals repeatability
- Damping of side forces through the elastomer mount
- Self-centering after side load
- Minimal effect on accuracy by side forces

VBB Load Cells 5 kg - 0,5t

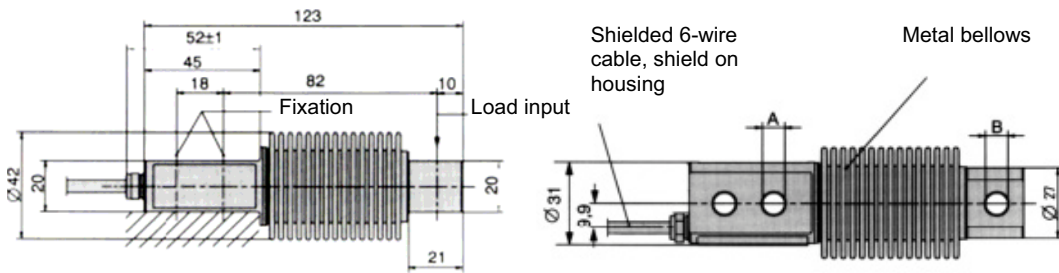

Variant	Dimensions (mm)	
	A	B
VBB 5 kg - 0,2 t	8,2	8,2
VBB 0,5 t	10,5	11,1

VEB Elastomer Mount 5 kg - 0,5 t for VBB Load Cells

Capacities 5 kg - 0,2 t

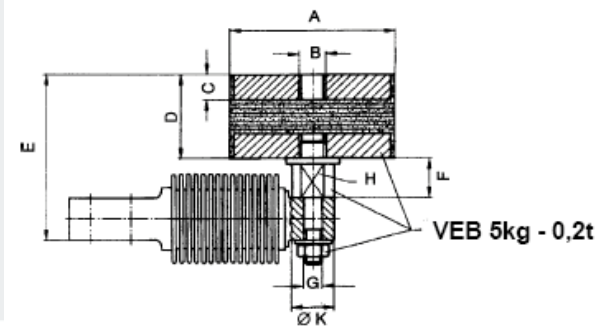

Capacity 0,5 t

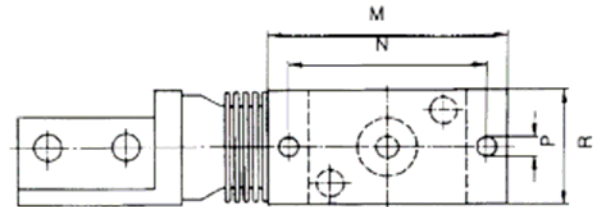
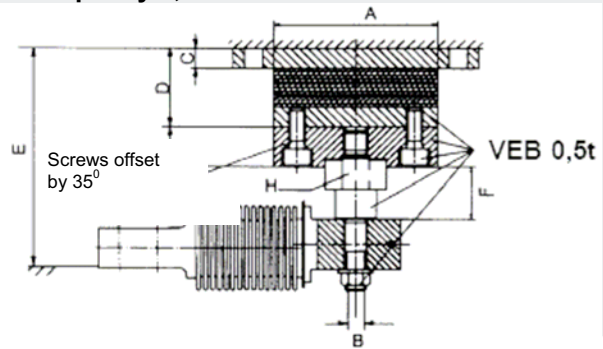

Elastomer mount correct mounting position

Dimensions (mm)

Elastomer mount	A	B	C	D	E	F	G	H	K	L	M	N	P	R	F _R *	S _{max} **
VEB 5 kg - 0,2 t	75	M12	12	40	79 ±1,3	18,5	M8	SW17	19	-	-	-	-	-	163	3
VEB 0,5t	80	10	10	39	105 ^{+2,1} _{-2,2}	26	-	SW27	-	20	120	100	9	60	400	4,5

*F_R Restoring force in N with 1mm lateral displacement

**S_{max}, in mm, maximum adm. lateral displacement if loaded with rated capacity

Technical Data

Rated capacity	E_{max}	5 kg - 0,5 t				
Accuracy class		D1	C3*	C4**	C6***	Reference
Nominal characteristic value	C_n	2mV/V + 20 μ V/V; -2 μ V/V	2 mV/V \pm 1 μ V/V			
Combined error	F_{comb}	0,05 %	0,02 %	0,013 %	0,01 %	C_n
Zero signal return after loading (30 min)	F_{dr}	\pm 0,049 %	\pm 0,016 %	\pm 0,012 %	\pm 0,008 %	C_n
Creep error during stress (30 min)	F_{cr}	\pm 0,049 %	\pm 0,016 %	\pm 0,012 %	\pm 0,008 %	C_n
Temperature coefficient of zero signal	TK_0	\pm 0,05%/10 K	\pm 0,0125%/10 K	\pm 0,009%/10 K	\pm 0,009%/10 K	C_n B B_{tn}
Temperature coefficient of characteristic value	TK_c	\pm 0,05%/10 K	\pm 0,008%/10 K	\pm 0,007%/10 K	\pm 0,004%/10 K	C_n B B_{tn}
Maximum number of increments in certified applications	n_{LC}	1000	3000	4000	6000	
Min. scale interval	v_{min}	0,036 %	0,009 %	0,0066 %	0,0066 %	E_{max}
Minimum utilisation rate	B_{amin}	36 %	27 %	26 %	39 %	E_{max}
Maximum utilisation rate	B_{amax}	$B_{amax} = E_{max}$				
Input resistance	R_e	350 Ω - 480 Ω				t_r
Output resistance	R_a	356 Ω \pm 0,2 Ω	356 Ω \pm 0,12 Ω			t_r
Zero signal	S_0	\pm 1 %				C_n
Maximum supply voltage	U_{smax}	18 V				
Nominal temperature range	B_{tn}	-10°C to +40°C				
Service temperature range	B_{tu}	-30°C to +70°C				
Reference temperature	t_r	23°C				
Storage temperature range	B_{ts}	-50°C to +85°C				
Safe load limit	E_L	150 %				C_n
Breaking load	E_D	300 %				C_n
Protection class		IP67 (tightened test conditions: 1 m water gauge; 100 h)				
Cable specification		3 m PVC cable, 6 wires, shielded, shield on housing				
Colour code		black : input - / blue : input + / yellow: shield red : output - / white : output + grey : sensor - / green : sensor +				
Corrosion protection		Stainless steel				

*: Quality C3 available for nominal loads \geq 10 kg only

** : Quality C4 available for nominal loads \geq 20 kg only

***: Quality C6 available for nominal loads \geq 50 kg only

Variants Load Cells	Order No.	Ex-Variants Load Cells	Order No.
VBB 5 kg D1	D 725 417.01		
VBB 10 kg D1	D 725 417.02		
VBB 10 kg C3	D 725 419.02	VBB 10 kg C3 „Ex“	D 725 420.02
VBB 20 kg D1	D 725 417.03		
VBB 20 kg C3	D 725 419.03	VBB 20 kg C3 „Ex“	D 725 420.03
VBB 50 kg D1	D 725 417.04		
VBB 50 kg C3	D 725 419.04	VBB 50 kg C3 „Ex“	D 725 420.04
VBB 0,1 t D1	D 725 409.01	VBB 0,1 t D1 „Ex“	D 725 409.11
VBB 0,1 t C3	D 725 409.04	VBB 0,1 t C3 „Ex“	D 725 409.14
VBB 0,1 t C4	D 726 370.01	VBB 0,1 t C4 „Ex“	D 726 370.11
VBB 0,2 t D1	D 725 409.02	VBB 0,2 t D1 „Ex“	D 725 409.12
VBB 0,2 t C3	D 725 409.05	VBB 0,2 t C3 „Ex“	D 725 409.15
VBB 0,2 t C4	D 726 370.02	VBB 0,2 t C4 „Ex“	D 726 370.12
VBB 0,2 t C6	D 726 370.04	VBB 0,2 t C6 „Ex“	D 726 370.14
VBB 0,5 t D1	D 725 409.03	VBB 0,5 t D1 „Ex“	D 725 409.13
VBB 0,5 t C3	D 725 409.06	VBB 0,5 t C3 „Ex“	D 725 409.16
VBB 0,5 t C4	D 726 370.03	VBB 0,5 t C4 „Ex“	D 726 370.13

Variants Elastomer Mounts	Order No.
VEB 5 kg - 0,2 t	D 725 408.01
VEB 0,5 t	D 725 408.02

Example for ordering: Rated Capacity 0,2 t, Accuracy Class C6: Variant VBB 0,2t C6 –
 Ordering Number D726 370.04
 Additional versions available upon request.