

## Elastomer Mounts for Ring-Torsion Load Cells



- Self-centering capability
- Dynamic load damping properties
- Minimal reaction to side forces
- Simple, rugged, and flat design
- High resistance to environmental influences and chemicals
- Insensitivity to inclined position of connecting structure up to  $0.6^\circ = 10 \text{ mm/m}$
- Easy installation
- Maintenance-free

### Application

The elastomer mounts are designed for load input to the Schenck ring-torsion load cells optimized with regard to measurement.

They are used with all kinds of industrial weighing systems, e.g. hopper scales, roller conveyor scales, crane scales, road weighbridges.

### Construction

The elastomer mounts consist of the load reception plate for load input, the elastomer for self-centering, and a base plate for load output to the supporting structure.

Lateral movement must be limited depending on the installation situation. Lifting off has to be prevented by using appropriate hold-downs.

### Functions

The weight to be measured is applied to the load cell via a load reception plate. Due to the special design, the vertical deflection is extremely low and proportional to the load.

Occurring side forces deform the elastomer in a parallel direction. The mount centers automatically when relieved of side force.

Depending on the admissible area pressure of the load receptor, it may be necessary to install a load distribution plate over the contact plate. The necessity for this measure must be checked each time when the load receptor is a concrete construction.

**Important:**

Lifting and lowering of the load application elements may cause a non-repeatable load to be applied to the load cell and entail measuring errors in the entire weighing system. Therefore, ensure that the load cell in the elastomer mount is never totally relieved. Select minimum preload such that load cell and contact plate, or base plate, are always positively tied.

- Elastomer is installed above the load cell
- Elastomer is bolted or welded to the connecting structure with two straps fitted on sides
- Height adjustment (max. 5 mm) via shims
- Alignment through shifting the base plate secured by bolted or welded fixing pieces

**Elastomer Mounts DEM 0.25 t – 0.50 t for RTB Load Cells**

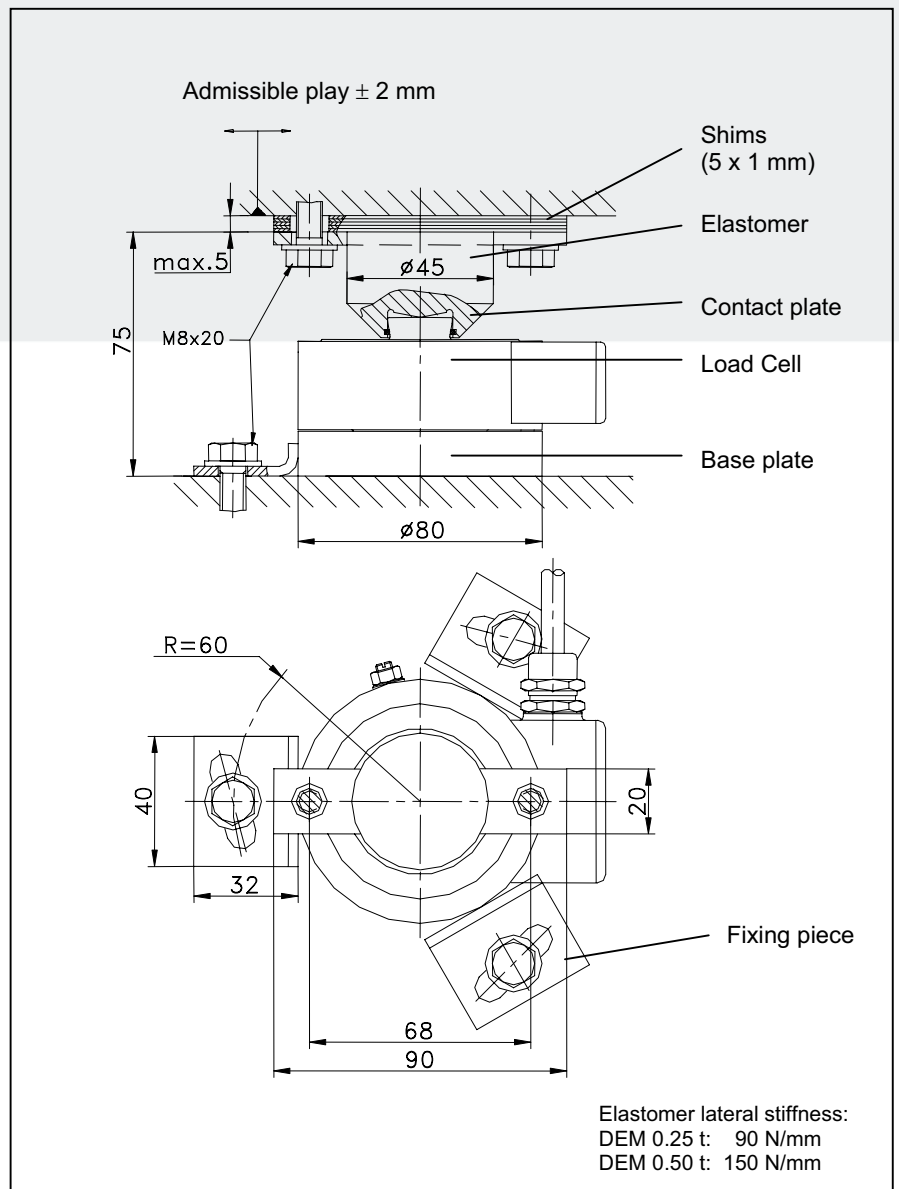

### Elastomer Mount VEN 1 t – 4.7 t for RTN Load Cells

- Elastomer is installed above the load cell.
- Elastomer is bolted or welded to the connecting structure with two straps fitted on sides
- Height adjustment (max. 5 mm) via shims
- Alignment through shifting the base plate secured by bolted or welded fixing pieces
- Alternatively, the fixing can be realized by using a centering pin
- The head and base plates of the elastomer mount can be screwed onto the connecting structure directly. Thanks to the optional weld-on plates, there is no need for drilling and thread cutting on the connecting structure. The weld-on plates are welded onto the structure after alignment of the load carrier, and their tap holes then accommodate the mount. The weld-on plates for the 1 - 4.7 t capacity range can be arranged above and/or below the VEN mount. 15 mm additional headroom is required for each plate.

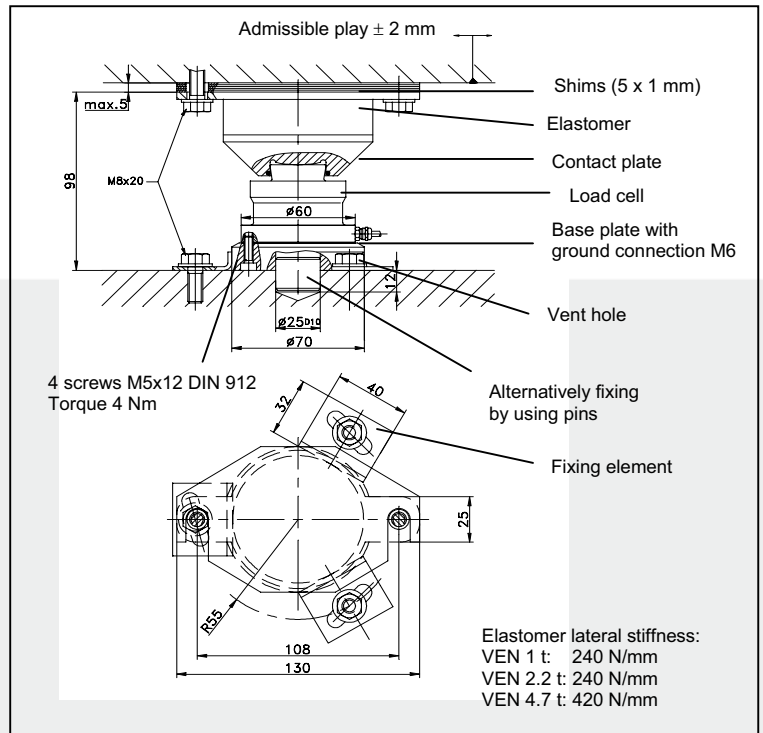

### Elastomer Mount VEN 10 t – 470 t for RTN Load Cells

- Elastomer is installed below the load cell
- Contact plate is secured by a centering piece bolted or welded onto the supporting structure
- Height adjustment (max. 5 mm) via shims
- Alignment through shifting the elastomer secured by bolted or welded straps
- The head and base plates of the elastomer mount can be screwed onto the connecting structure direct. Thanks to the optional weld-on plates, there is no need for drilling and thread cutting in the connecting structure. The upper weld-on plate is welded onto the structure after alignment of the load carrier, and its tap holes then accommodate the mount. On the mount underside, the elastomer is welded on directly. Additional headroom required for the weld-on plate:  
 VEN 10-22 t: 20 mm  
 VEN 33 t: 25 mm  
 Other rated capacities available on request.

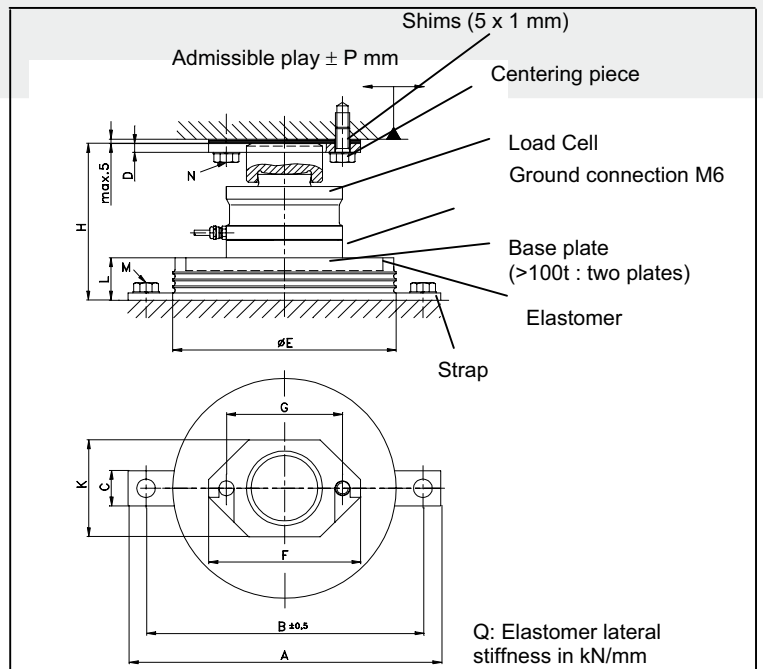

Type VEN	Dimension (mm)													
	A	B	C	D	E	F	G	H	K	L	M	N	P	Q
10-22	190	170	25	6	130	90	68	130	60	41	M10x25	M10x25	6	1.4
33	280	250	25	6	170	120	90	168	80	56	M12x25	M12x25	6	1.7
47	350	310	40	10	250	170	130	198	110	63	M16x30	M16x30	6	3.1
68	350	310	40	10	250	170	130	220	110	63	M16x30	M16x30	6	3.1
100	400	360	40	10	300	180	140	239	130	68	M16x30	M16x30	6	4.3
150	510	460	50	10	400	180	140	320	130	81	M20x45	M16x30	8	6.8
220	560	510	50	12	450	260	200	373	180	81	M20x45	M20x45	8	8.7
330	680	620	60	12	550	260	200	428	180	96	M24x40	M24x40	10	7.3
470	780	720	60	12	650	320	240	520	220	115	M24x40	M24x40	13	7.7

### Technical Data

Type:	DEM	VEN	VEN
Rated capacity:	0.25...0.50 t	1...100 t	150...470 t
Weight: (including load cell)	DEM 0.25 – 0.50 2.8 kg	VEN 1-4.7 4.8 kg VEN 10-22 7 kg VEN 33.....18 kg VEN 47 33 kg VEN 68 35 kg VEN 100 50 kg	VEN 150 115 kg VEN 220 200 kg VEN 330 330 kg VEN 470 600 kg
Material:	Galvanized steel (VEN 1-4.7 t: stainless steel); Contact plate stainless steel Neoprene (chlorine butadiene rubber)		
Metal parts	Metal parts: All stainless steel		
Elastomer	Elastomer: FKM (fluorinated) SBR (Styrene-butadiene rubber) EPDM (ethylene propylene diene rubber)		
Options: (available upon request)			
Nominal temperature range	-10°C to +40°C		
Service temperature range	-30°C to +80°C		
Deflection	≤ approx. 0.8 mm at rated capacity		

### Variants / Ordering Nos.

DEM 0.25	V041386.B01	VEN 33	D 725575.02
DEM 0.50	V041387.B01	VEN 47	D 725575.03
VEN 1	D 726185.01	VEN 68	D 725575.04
VEN 2,2	D 726185.01	VEN 100	D 725575.05
VEN 4,7	D 726185.02	VEN 150	D 726186.01
VEN 10-22	D 725575.10	VEN 220	D 726186.02
VEN 10-22	D 725575.11*	VEN 330	D 726186.03
		VEN 470	D 726186.04

### Optional weld-on plates:

VEN 1-4.7 t St 37: D733120.01

VEN 1-4.7 t 1.4301: D733120.06

VEN 10-22 t St 37: D733120.02

VEN 10-22 t 1.4301: D733120.04

VEN 33 t St 37: D733120.03

Other rated capacities and materials available on request.

(load cell is not included in the delivery)

\*Metal part stainless steel